

"TASDIQLAYMAN"

"Sho'rtan GKM" MChJ  
Bosh direktor o'rinbosari

N. Xalilov

2023 yil.

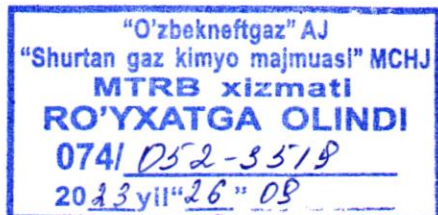

"Sho'rtan GKM" MChJ ehtiyoji uchun  
santexnika vositalarini xarid qilish uchun

***TEXNIK TOPSHIRIQ***

2023 y.

## 1. UMUMIY QOIDALAR

### 1.1. Xarid qilishning asosi va maqsadi

Asos: 2023 yillik buyurtmalar.

### 1.2. Yangiligi to'g'risida ma'lumot (ishlab chiqarilgan yili)

Santexnika vositalari 2023 yilda ishlab chiqarilgan bo'lishi lozim.

## 2. ASOSIY TEXNIK TALABLAR

### 2.1 Smesitel dush uchun – 25 dona.

**Umumiy xususiyatlar**  
Turi: dush jamlanmasi  
Rangi : xrom  
Ustki qismi: yaltiroq  
Materiali : Latun  
Dush nasadkasi diometri: 12.5sm  
Shlang uzunligi: 180sm  
Tepa qismidagi dush nasadkasi diometri: 225sm  
Dush balandligi: 970sm  
Dush nasadkasi : 3 xil  
Suv ta'minoti: eksantriklar 1/2"

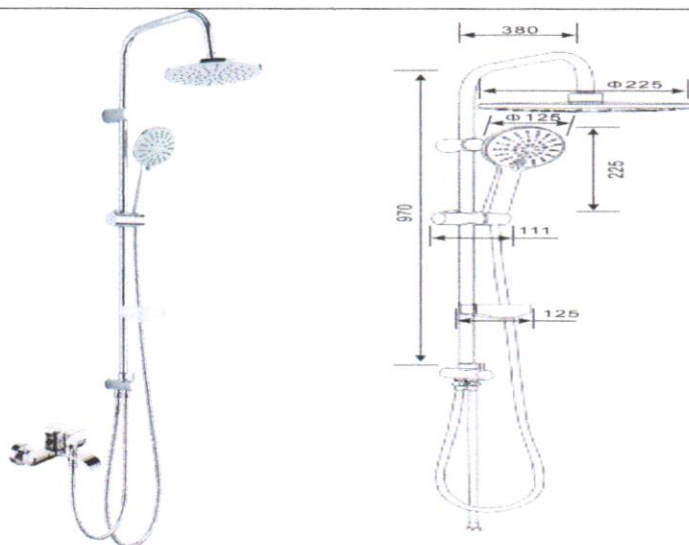

### 2.2 Smesitel vanna uchun – 35 dona.

**Umumiy xususiyatlar**  
Boshqargichi: yagona tutqichli  
Rang: Xrom  
Yaltiroq sirtli  
Material: Latun  
O'rnatish: Devorga  
Quvur uzunligi: 37.9 sm  
Shakli: to'rtburchakli  
Shlang uzunligi: 150sm  
Dush nasadkasi diometri: 12.5sm

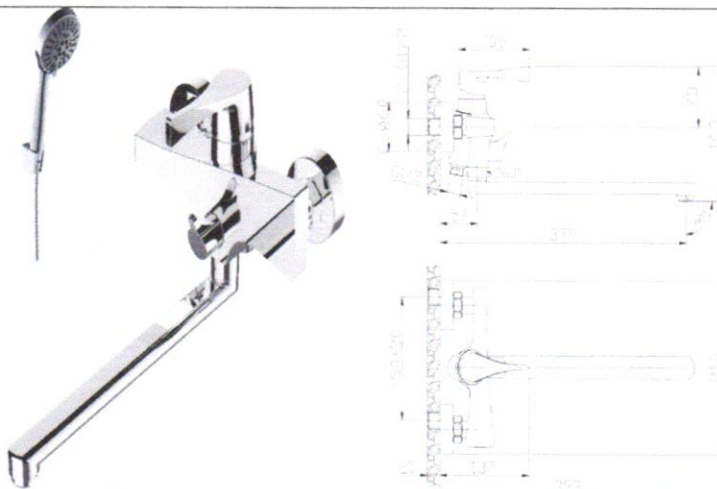

### 2.3 Smesitel rakavina uchun – 170 dona.

**Umumiy xususiyatlar**  
Boshqargichi: yagona tutqichli  
Rang: Xrom  
O'rnatish: rakavinaga  
Quvur uzunligi: 12 sm  
Quvur balandligi: 10 sm  
Og'irligi: 0.66 kg

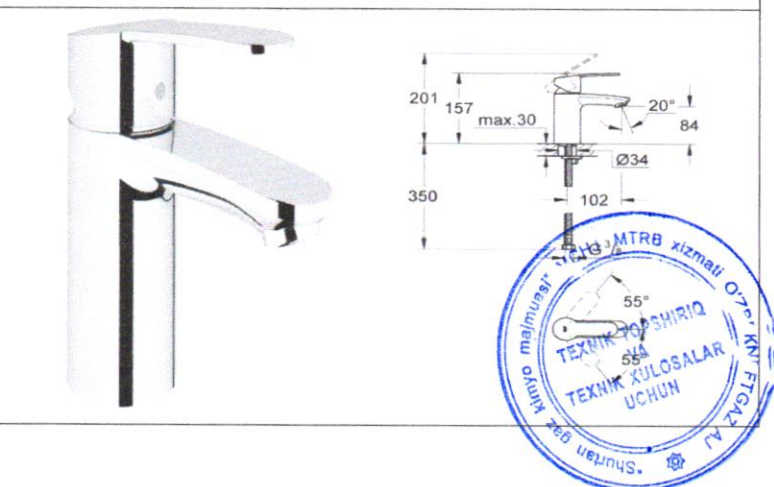

**2.4 Smesitel uchun kran buksa (15dm) – 30 dona.**

**Umumiy xususiyatlar**  
Dyumi: 15Ø  
Materiali: latun  
Og`irligi: 300g  
Qo`l yuvish jixozini kranlarining  
extiyot qismlarini

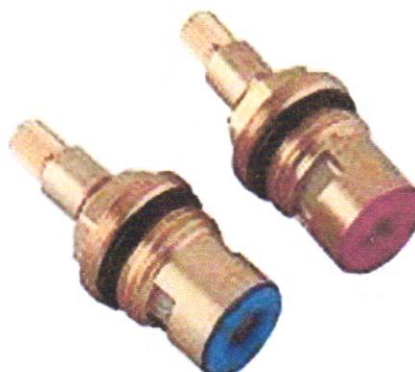

**2.5 Shlang rakovina uchun (70sm) – 381 dona.**

**Umumiy xususiyatlar**  
Shlanga o`ralgan material: kapronli  
Ulanishi: ichki va tashqi rezba  
Uzunligi: 70 sm  
Shlang turi: kranlar uchun



**2.6 Shlang unitaz uchun kapronli, uzunligi 80sm – 78 dona.**

**Umumiy xususiyatlar**  
Shlanga o`ralgan material: kapronli  
Uzunligi: 80 sm  
Ulanishi: ichki rezbali  
Shlang turi: kranlar uchun

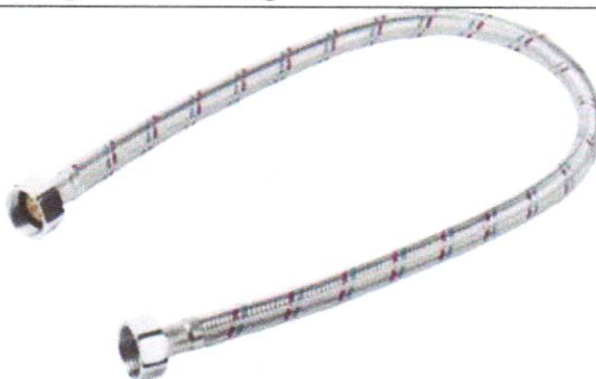

**2.7 Shlang slivnogo bochka uchun kapronli, (dlina 90 sm) – 46 dona.**

**Umumiy xususiyatlar**  
Shlanga o`ralgan material: kapronli  
Uzunligi: 90 sm  
Ulanishi: ichki rezbali  
Shlang turi: kranlar uchun



### 2.8 Sifon unitaz uchun – 56 dona.

**Umumiy xususiyatlar**  
 Hojatxona uchun  
 Rangi: Oq  
 Tuzilishi: Gofrirovka qilingan  
 Uzunligi: 22sm  
 Kengligi: 11sm  
 Drenaj diametrik: 10 sm  
 Materiallar: plastik  
 Uzunlikni sozlash: 21sm  
 Kanalizatsiya trubasiga ulanish: 11sm  
 Qo'shimcha funktsiyalar: uzunlikni sozlash

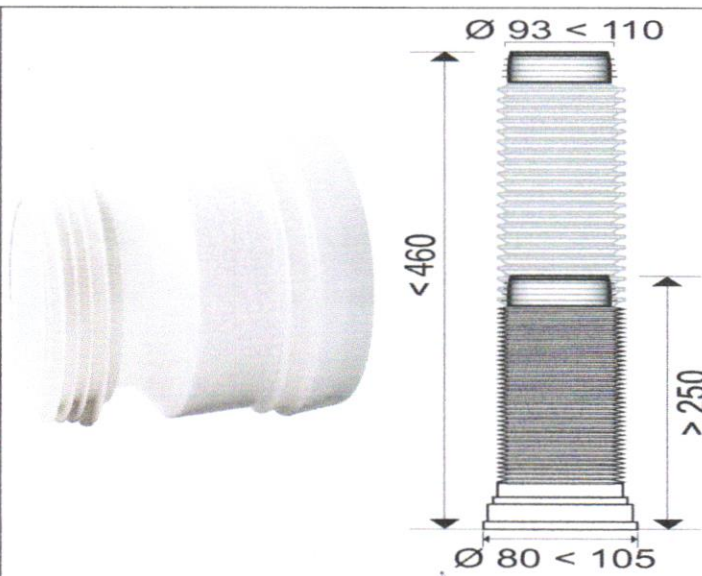

### 2.9 Sifon rakovina uchun, plastmassa-116 dona

**Umumiy xususiyatlar**  
 Sifon rakovina uchun  
 Rangi: Oq  
 Uzunligi: 71sm  
 Balandligi: 14sm  
 Materiallar: plastic  
 Tuzilishi: Gofrirovka qilingan shlang qismi

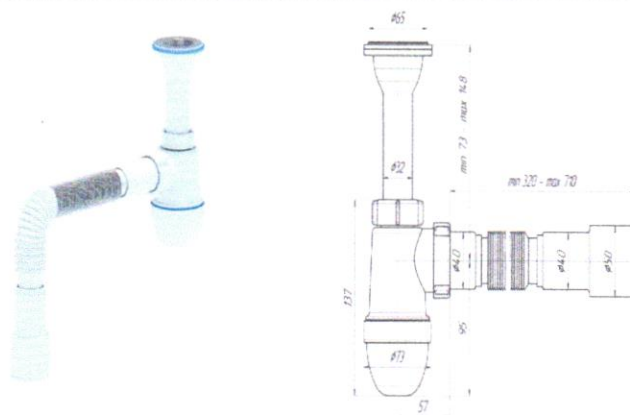

### 2.10 Sifon vanna uchun, plastmassa-40 dona

**Umumiy xususiyatlar**  
 Sifon vanna uchun  
 Drenaj oqimining turi: avtomatik  
 Rangi: Oq  
 Shakli: Dumaloq  
 Hidrozatvorli  
 Uzunligi: 71 sm  
 Balandligi: 42.2 sm  
 Drenaj diametric: 5,2 sm  
 Ulanish diametri: 5 sm  
 Materiali: zanglamaydigan po'latdir  
 Uzunlikni sozlash: 39sm

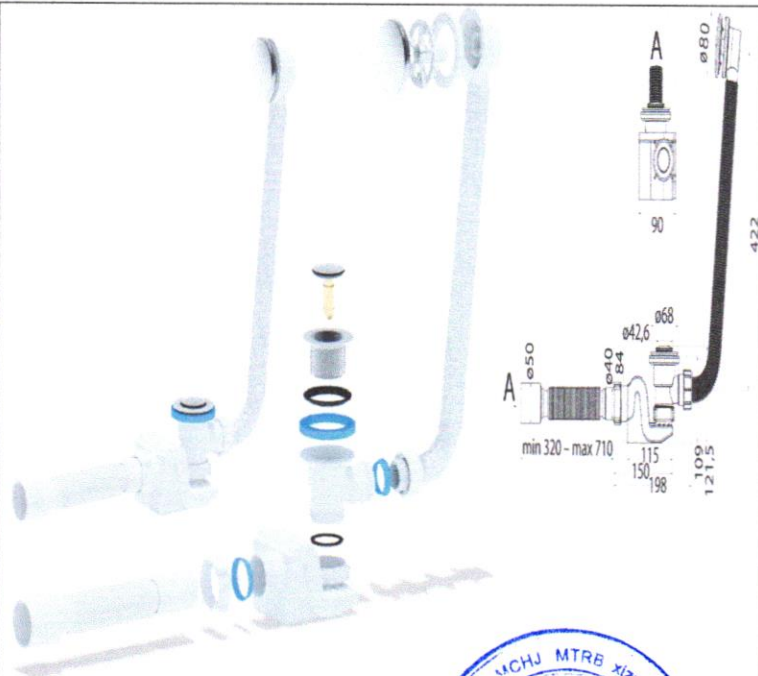

### 2.11 Sifon dush uchun – 6 dona.

**Umumiy xususiyatlar**  
Sifon dush uchun  
Rangi: Oq  
Uzunligi : 73.5sm  
Balandligi: 8.2sm  
Drenaj diametri: 5 sm  
Material: zanglamaydigan po'lat  
Kanalizatsiya trubasiga ulanish: 5sm  
Yuqori o'tkazish qobiliyati: 45 l/min  
Qo'shimcha funktsiyalar:  
korroziyaga qarshi qoplama

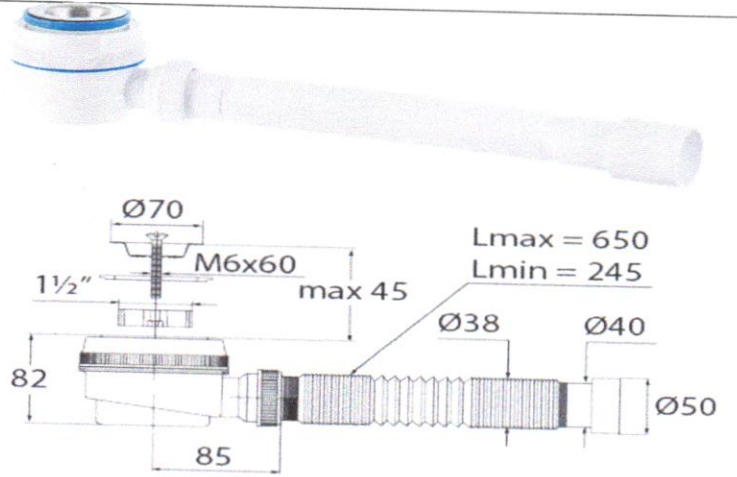

### 2.12 Hojatxona urindig'i plastmassa– 8 dona.

**Umumiy xususiyatlar**  
Hojatxona urindig'i  
Rangi: Oq  
Shakli: oval  
Uzunligi: 44.5sm  
Kengligi: 35.5  
Material: plastmassa

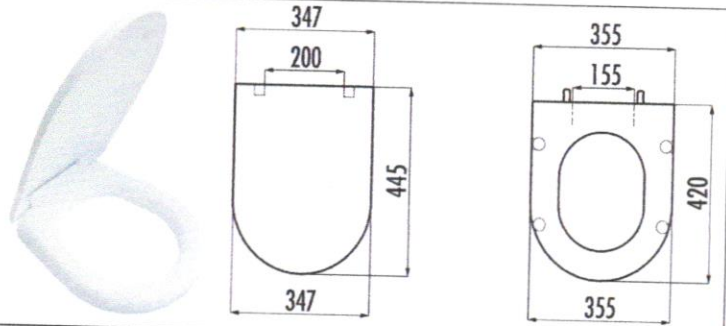

### 2.13 Shlang smesitely uchun kapronli uzunligi 120 sm-6 dona Shlang smesitely uchun kapronli uzunligi 50 sm -8 dona Shlang smesitely uchun kapronli uzunligi 30 sm -16 dona

**Umumiy xususiyatlar**  
Ulanishi: ichki va tashqi rezba  
Uzunlugu: 120,50,30 sm  
Shlanga o'ralgan material: kapronli  
Shlang turi: kranlar uchun

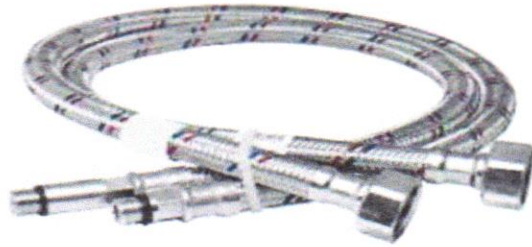

### 2.14 Poplavok unitaza uchun – 9 dona.

**Umumiy xususiyatlar**  
Material: Plastik  
Uzunligi: 20sm  
Balandligi: 32.5 sm  
Kengligi: 8.5 sm  
Suvni to'kish rejimi: bitta tugma  
(start-stop)  
Suv ta'minoti: yon tomonidan  
Drenaj mexanizmi: mexanik tugma  
O'rash bilan og'irligi: 0.65 kg  
Hajmi: 0.00459 m<sup>3</sup>

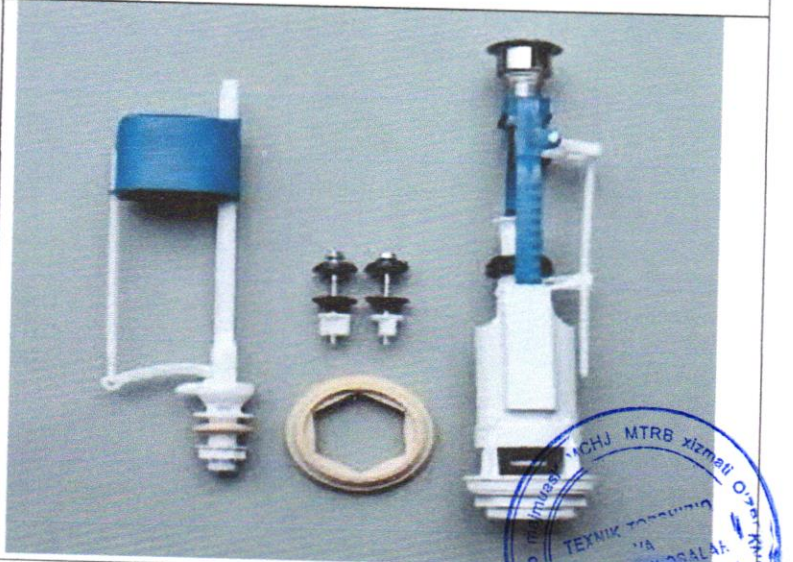

### 2.15 Rezinli gilamcha dush uchun 70sm x 70sm– 26 dona.

**Umumiy xususiyatlar**  
Rangi: qora  
Balandligi: 15 mm  
Material: rezina  
Hujayra kataligi: o'rtacha  
O'lchami 70x70



### 2.17 Shlang Sug`orish uchun diametr 20 rezinali-260 metr Shlang Sug`orish uchun diametr 25 rezinali-920 metr Shlang Sug`orish uchun diametr 40 rezinali-40 metr Shlang Sug`orish uchun diametr 32 rezinali-100 metr

**Umumiy xususiyatlar**  
Shlang Sug`orish ishlari uchun,  
issiq sovuq xavoga chidamli  
Rang: Qora  
Materiali : rezinali, ich qismi ipli  
Diametri : 20,25,40,32

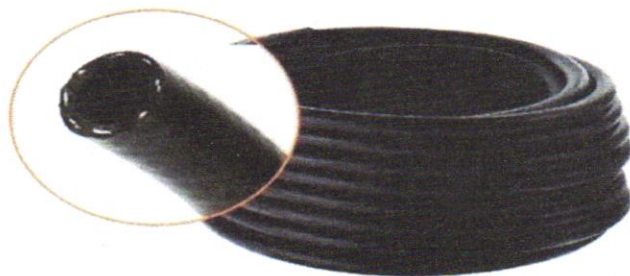

## 3. QO'SHIMCHA TALABLAR

### 3.1 Yorliqqa talablar

Moddiy texnik bazalarining-Yorliqida quyidagilar mavjud bo'lishi kerak:

- Mahsulot nomi;
- Ishlab chiqarilgan joy nomi;
- Ishlab chiqargan korxonaning mahsulot nishoni (mavjudligi);
- Moddiy texnik bazalarning sifati;
- Kafolat muddatlari;
- Kafolat tamg'asi;
- Shartli belgilari;
- Ishlab chiqaruvchining yuridik manzili;
- Texnik shartlari ko'rsatilgan yo'riqnomasi.

### 3.2 Sifat va qadoqlashga qo'yilgan talablar

Sifat standartlari mavjud bo'lishi kerak. Iste'molchi bilan kelishilgan holda o'zgartirishlar kiritilishi mumkin.  
Har bir mahsulotni tashish va saqlashda, nanga chidamli qadoqlash materialiga o'ralishi kerak.



#### 4. YETKAZIB BERISH VA QABUL QILISHGA TALABLAR

Mahsulot qabul qilish xaridor hududida, komissiya tomonidan amalga oshiriladi. Yetkazib berilayotgan mahsulot yangi qadoqlangan va mahsulot nishoni bo'lishi hamda sifatsiz bo'lmasligi kerak. Agar mahsulot sifatsiz bo'lsa xarid qiluvchi tomonidan qaytarilishi va yetkazib beruvchi tomonidan almashtirilishi zarur.

#### 5. TASHISHGA TALABLAR

Avtotransport vositasida yuk tashish qoidalariga mos hamda yopiq holatda bo'lishi shart.

#### 6. KAFOLAT MUDDATI TALABLARI

Har bir mahsulotga yetkazib beruvchi tomonidan kamida 12 oylik kafolat muddati berilishi shart.

#### TAYYORLADI :

MXX boshlig'i:

 I. Xalilov

MXX omborchisi:

 M. Elmuradov

UJF boshlig'i:

 E. Chorshanbiyev

UJF boshliq o`rinbosari:

 U. Bo`riyev

UJF omborchisi:

 E. Rasulov

MTRB xizmati muhandisi:

 A. Ostonov

